

Tools for Pipe Welding



2017

Pipe Welding Clamps

DWT pipe clamps (for steel pipes)



Due to its unique design, the pipe alignment clamp ensures that the clamping forces are evenly spread round the pipe in welding process, because the distance between clamping points are exactly the same. This is true for all pipe dimensions within the range of the clamp (1 to 14 inches).

The adjusting screws have stainless steel balls at their ends. This eliminates the scratching of the objects to be welded, and no corrosion will occur.



Part.-No.	Description
RG350009	Screw for DWT Steel Clamp SC13
RG350010	Screw for DWT Steel Clamp SC25 & 47
RG350011	Screw for DWT Steel Clamp SC59 & 1014

The pipe alignment clamp can be used for the welding of all kinds of materials such as carbon steel, stainless steel, duplex, super duplex and titanium.

Part.-No.	Description	Range (inch)	Range (mm)	Weight (kg)	Weight (lb)	Material
RG350004	Pipe welding clamp steel DWT SC13	1 - 3	25 - 76	1,5	3.00	Steel
RG350005	Pipe welding clamp steel DWT SC25	2 - 5	51 - 127	3,1	6.83	Steel
RG350006	Pipe welding clamp steel DWT SC47	4 - 7	102 - 177	3,3	7.28	Steel
RG350007	Pipe welding clamp steel DWT SC59	5 - 9	127 - 228	6,9	15.21	Steel
RG350008	Pipe welding clamp steel DWT SC1014	10 - 14	254 - 355	9,0	19.84	Steel

Pipe clamps (for stainless steel pipes)



Part.-No.	Description	Range (inch)	Range (mm)	Weight (kg)	Weight (lb)	Material
RG350012	Pipe welding clamp for SS pipes DWT-SS13	1 - 3	25 - 76	1,0	2.20	Aluminum
RG350013	Pipe welding clamp for SS pipes DWT-SS26	2 - 6	51 - 152	3,5	7.71	Aluminum
RG350014	Pipe welding clamp for SS pipes DWT-SS614	6 - 14	152 - 355	8,0	17.63	Aluminum

Single Pipe Chain Clamps

Pipe chain clamp - complete (incl. swivel & Terminal member)

Part.-No.	Description	Range	No. jackbars
RG350040	Single manual pipe chain clamp	8 - 10"	5
RG350041	Single manual pipe chain clamp	8 - 12"	6
RG350042	Single manual pipe chain clamp	8 - 16"	7
RG350043	Single manual pipe chain clamp	8 - 20"	9
RG350044	Single manual pipe chain clamp	8 - 24"	11
RG350045	Single manual pipe chain clamp	8 - 28"	13
RG350046	Single manual pipe chain clamp	8 - 32"	14
RG350047	Single manual pipe chain clamp	8 - 36"	16
RG350048	Single manual pipe chain clamp	8 - 40"	18
RG350049	Single manual pipe chain clamp	8 - 44"	19
RG350050	Single manual pipe chain clamp	8 - 48"	21
RG350051	Single manual pipe chain clamp	8 - 52"	23
RG350052	Single manual pipe chain clamp	8 - 56"	25
RG350053	Single manual pipe chain clamp	8 - 60"	26



Swivel

Spare parts

Part.-No.	Description
on request	Single chain clamp for medium wall, 1275 mm long, without swivel, 7 jackbars
	Swivel
	Single jackbar
	Two-parts Terminal member
	Three-parts Chain extension
	Terminal member with jackbar, 137 mm long
	Chain extension, 177 mm long with jackbar



Two-parts terminal member



Three-parts chain extension

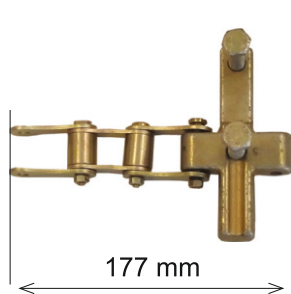

Chain extension with jackbar

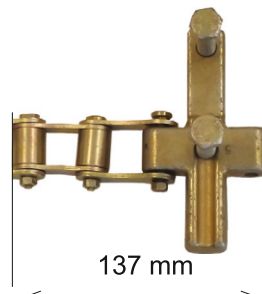

Terminal member with jackbar

Double Pipe Chain Clamp

Pipe chain clamp - complete (incl. swivel & terminal member)



Part.-No.	Description	Range	No. jackbars
RG350054	Double manual pipe chain clamp	8 - 12"	6
RG350055	Double manual pipe chain clamp	8 - 16"	7
RG350056	Double manual pipe chain clamp	8 - 20"	9
RG350057	Double manual pipe chain clamp	8 - 24"	11
RG350058	Double manual pipe chain clamp	8 - 28"	13
RG350059	Double manual pipe chain clamp	8 - 32"	14
RG350060	Double manual pipe chain clamp	8 - 36"	16
RG350061	Double manual pipe chain clamp	8 - 40"	18
RG350062	Double manual pipe chain clamp	8 - 44"	19
RG350063	Double manual pipe chain clamp	8 - 48"	21
RG350064	Double manual pipe chain clamp	8 - 52"	23
RG350065	Double manual pipe chain clamp	8 - 56"	25
RG350066	Double manual pipe chain clamp	8 - 60"	26



Swivel

Spare parts

Part.-No.	Description
on request	Double chain clamp for medium wall, 1275 mm long, without swivel, 7 jackbars
	Swivel
	Single jackbar
	Two-parts terminal member
	Three-parts chain extension
	2 x terminal member, 137 mm long with jackbar
	2 x chain extension, 177 mm long with jackbar



Two-parts terminal member



Three-parts chain extension

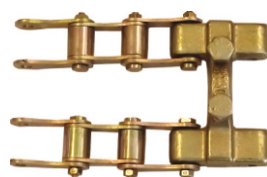

177 mm
2 x Chain extension with jackbar

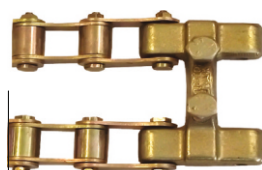

137 mm
2 x Terminal member with jackbar

Internal Spider Welding Clamps

Internal Spider Clamp (ISC) for welding flanges to pipes. The clamp has a range from 2.25" (56 mm) and up to 37" (940 mm). The ISC can be used for stainless steel and carbon steel pipes because the contact points of the systems are made of stainless steel.

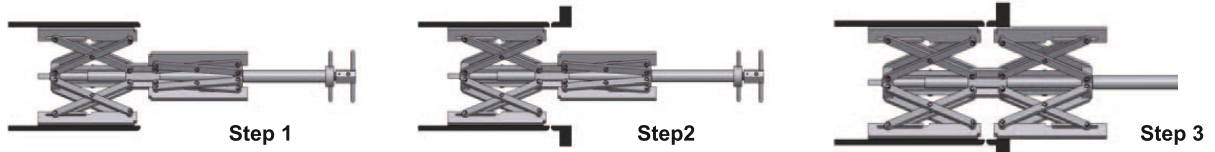

Part.-No.	Description	Range I.D.		Weight	
		mm	inch	kg	lb
RG350015	Spider pipe clamp ISC56140	56 - 140	2.5 - 5.5	1,35	2.7
RG350016	Spider pipe clamp ISC85220	85 - 220	3.3 - 8.6	4	8
RG350017	Spider pipe clamp ISC120350	120 - 350	4.7 -13.8	12	24
RG350018	Spider pipe clamp ISC180520	180 - 520	7 - 20.4	27	54

Internal Spider Elbow Clamp (ISEC) suitable for clamping flanges to bends. Fast and easy tool. The ISEC can be used for stainless steel and carbon steel pipes because the contact points of the systems are made of stainless steel.



Part.-No.	Description	Range I.D.		Weight	
		mm	inch	kg	lb
RG350019	Spider elbow pipe clamp ISEC56115	56 - 115	2.2 - 4.5	1	2
RG350020	Spider elbow pipe clamp ISEC85195	85 - 195	3.3 - 7.6	3	6
RG350021	Spider elbow pipe clamp ISEC120315	120 - 315	4.7 - 12.4	10	20
RG350022	Spider elbow pipe clamp ISEC180520	180 - 520	7 - 20.4	24	48

Scissor Pipe Clamp - SPC

The Scissor Pipe Clamp for orbital welding or normal welding is able to clamp pipes of different dimensions. The range of the clamps is from 0,4" (10mm) up to 5,5" (140mm). It can be used on all types of materials as only stainless steel comes in contact with the pipe.

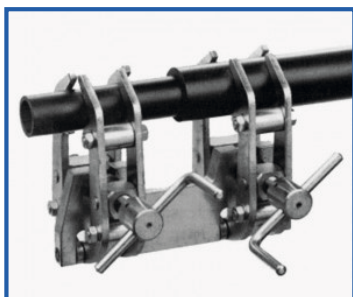

Part.-No.	Description	Range I.D.		Weight	
		mm	inch	kg	lb
RG350025	Scissor pipe clamp SPC1070	10 - 70	0.4 - 2.7	2,2	4.4
RG350026	Scissor pipe clamp SPC40140	40 - 140	1.5 - 5.5	5,7	11.4

Pipe Stand (foldable)



All pipe stands are delivered with a standard V-head and safety ring to prevent from sudden collaps and from hand injuries. The foldable Type allows easy storage and transportation. The carrying capacity of the Pipe Stand is 1130 kg. Choice of interchangeable head styles. (Roller kits)



Part.-No.	Description	Weight		Min. Height		Max. Height	
		kg	lb	cm	inch	cm	inch
RG350000	Pipe stand, folable legs DWT-FOLD1	11	24,3	41	16,1	86	33,9

Roller kits



Stainless steel balls



Steel rollers

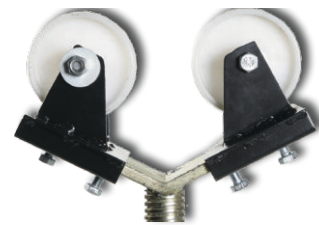

Polyethylene rollers

Part.-No.	Description	Capacity		Pipe Size		Weight (1 pc.)	
		kg	lb	mm	inch	kg	lb
RG350001	Stainless steel balls	925	2040	12 - 610	1/2 - 24	1,8	3.9
RG350002	Steel rollers	450	992	10 - 610	3/8 - 24	1,3	2.8
RG350003	Polyethylene rollers	450	992	12 - 610	1/2 - 24	1,1	2.4

Mobile Pipe Stand - Max Stand

The versatile Maxi Flex Stand - mobile pipe stand is the ideal fabricator stand. The large 300 mm vee head and heavy duty five-legged design offers the welder a maximum margin of safety on pipe up to 900 mm.

With optional accessories, such as the heavy duty casters and Hold-Down Device, pipe weighing 2.000 kg per Maxi Flex Stand can be wheeled with ease from storage rack... to welding bay... and onto the shipping dock. This means the load is lifted only once, resulting in a reduction of 50% or more in handling costs. The Maxi Flex Stand - mobile pipe stand is great for leveling loads for fit-up, or use with a pipe rotator.



Part.-No.	Description	weight / kg
RG350075	Pipe stand MAX STAND	55

Mobile pipe stands: In the shop or on the job, moving long lengths of pipe is a snap with Maxi Flex Stand!

Pipe Stand Fat Jack

- 5,000 lb (2,270 kg) vee head capacity
- foldable
- Adjustable Height Range 38" to 52" (96 to 132 cm)
- Ribbed Vee
- Ideal for Large Pipe up to 36" (900 mm)

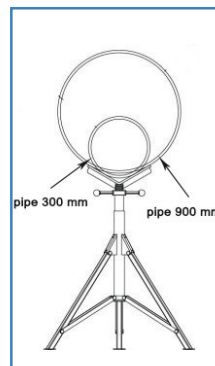

Part.-No.	Description	Weight	Min. height	Max. height	weight capacity
RG350080	Fat Jack with Vee head	17,6 kg	810 mm	1.820 mm	2.270 kg

Pipe Stand - Pro Roll



Adjustable height

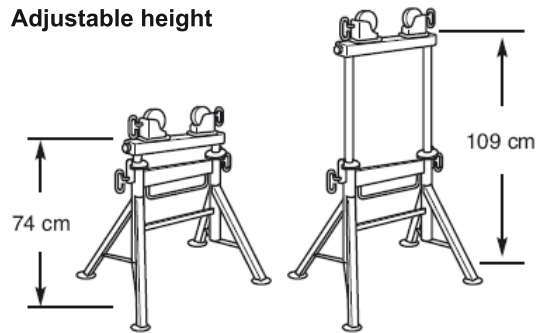

- Adjustable height
- up to 900 kg capacity
- Leveling on either side of stand
- uses quick change housing

Quick change rollers you have to order separately

Part.-No.	Description	weight / kg
RG350085	Pro Roll	16,4
RG350086	Pro Roll - Tableversion	10,9



*without Quick Change Rollers



Quick Change Rollers



Steel



Rubber



Stainless steel



Stainless steel transfer heads

Part.-No.	Description	weight / kg
RG350087	Quick change housing with rubber wheels	3,2
RG350088	Quick change housing with steel wheels	3,6
RG350089	Quick change housing with stainless steel wheels	3,6
RG350090	Quick change housing with stainless steel ball transfer head	3,6

Centering Head



Finding the exact position on a pipe has always been a problem. DWT Centering Head solve this problem in an easy manner. It can also be used to find any given points at angles from the top of the pipe. Can be used on all pipes from 1/2" and smaller.

Part.-No.	Description
RG350032	Centering Head DWT
RG350033	Centering Head DWT, digital

Flange Leveler

WT Flange Leveler is always a good tool to have. The WT Flange Leveler can be used for flanges with bolt holes from 16 mm and larger. With this design you avoid the chance of misplacing loose parts, and you will have no need of using adjusting tools.



Part.-No.	Description	Length in cm	Height in cm	Depth in cm	Lenght of pin in cm
RG350030	Flange Leveler	40	5	2,3	7,5
RG350031	Digital Flange Leveler	40	5	2,3	7,5

Rotary Ground Clamp

- Rotary head turns with the pipe - puts an end to ground lead twist, tangle and wear
- Provides quick, positive ground for roll-out welding of pipe and fittings - eliminates weld pinholes caused by poor grounding
- Attaches and detaches in seconds
- Makes up ground leads three ways - lug - clamp-on and bare cable
- Positive anti-arc bearings take loads up to 400 amps

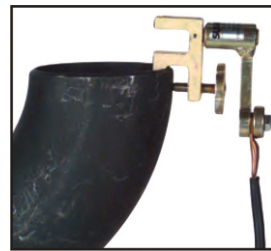
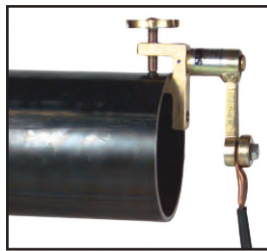
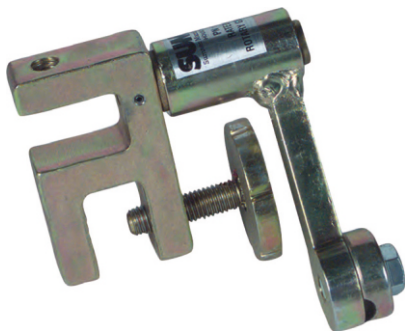

Part.-No.	Description	AMP	Weight (kg)	Weight (lb)
RG350034	Rotary earth clamp 400 Amp	400	2,3	4,6

Contact:

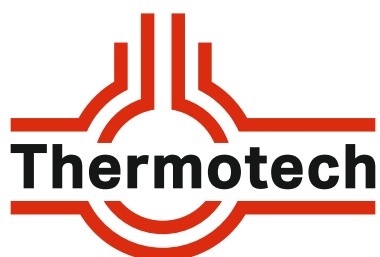

Thermotech Baltic OÜ

Sinikivi tee 12
Lehmja küla, Rae vald
75306 ESTONIA

Ph. +372 6003704
www.thermotech.ee
info@thermotech.ee